



GRP Water Tank Specialists

Victoria Mill, Lincoln Street, Preston, Lancashire PR1 6RE
Telephone: 01772 825757 Fax: 01772 204967



DECCAkare

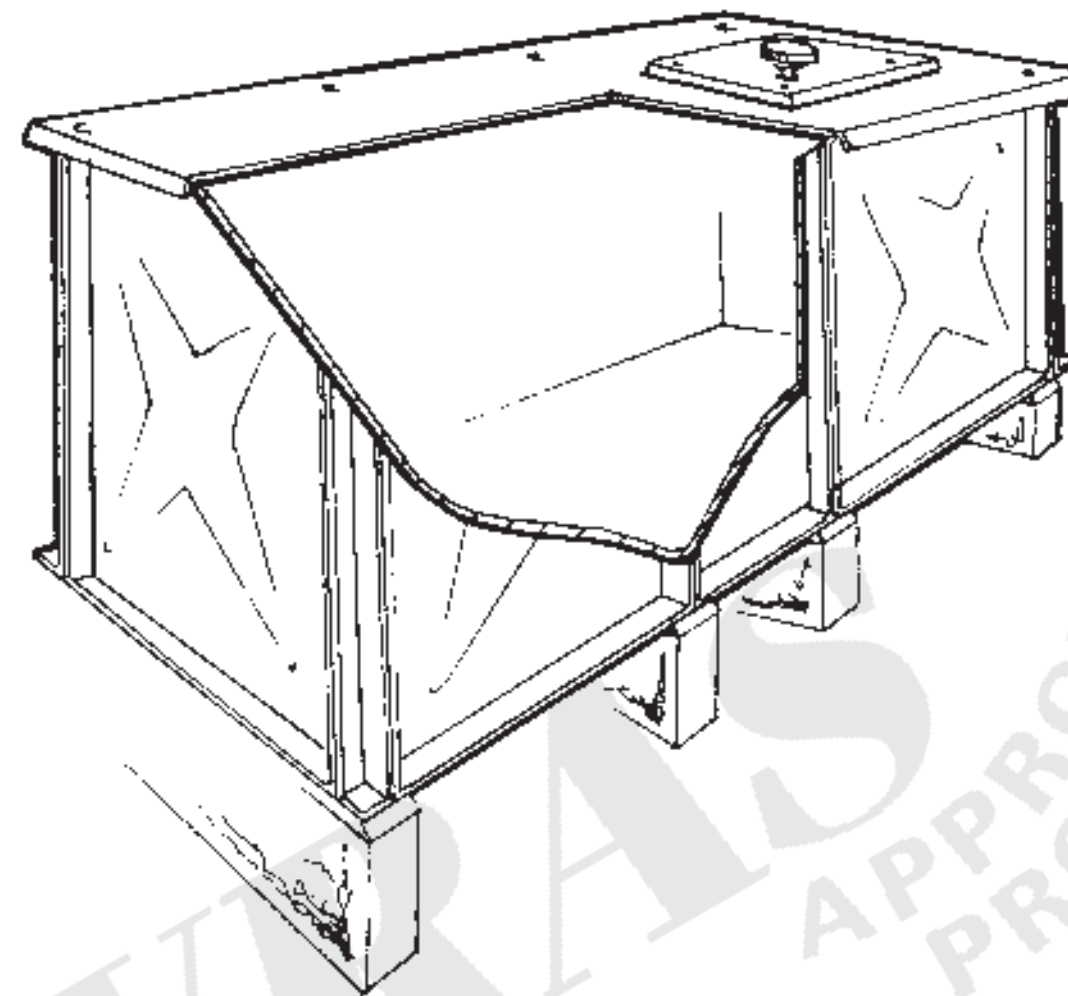

Presented by:



GRP Water Tank Specialists

Victoria Mill, Lincoln Street, Preston, Lancashire PR1 6RE
Telephone: 01772 825757 Fax: 01772 204967

Re. DECCAkare.01

Product Leaflet



DECCAkare

WRAS
APPROVED
PRODUCT

30
years
of Excellence



Introduction

DECCAkare provides the complete package to service your requirements for tank maintenance. Having been in the tank industry for 30 years, we are fully aware of the requirements of the latest water regulations.

DECCAkare will provide any combination of these features to suit the individual circumstances.

Our Site Engineers are experienced in the field of tank maintenance and provide a professional approach and understanding of the importance of a **clean environment**.

Operations are covered by our Health & Safety policy and are fully guaranteed.

We maintain a high standard of co-operation with all our clients to ensure that working practices are completed within the framework of the systematic planning of the installation with the minimum of inconvenience and disruption to the occupants of the building.

Specifications of Package

- Consultancy Services
- Lining
- Tank cleaning and painting
- Tank replacement
- New Byelaw 30 covers
- Commissioning
- Chlorinating
- Certificates
- Periodic tank maintenance programmes

Consultancy

Our range of services to our customers is backed up by our consultancy services technical department, feasibility studies and damage assessment reports.

Stripdown & Rebuild

Application for stripping down and dismantling of existing tank(s) is also

available if an existing tank is beyond repair or reline.

This tank will then be replaced with a new GRP water storage tank to your specification.

Chlorinating Service

A new addition to our service(s) is the Chlorination of tank(s) and associated pipework if required. All to (BS 6700).

Complete Reline

**DON'T SCRAP IT,
LINE IT WITH DECCABOARDS!**

The highlight of DECCAkare Maintenance Scheme is its complete relining of existing ageing or problematic water tanks which cannot be removed thus giving them a new lease of life.

Typical Properties

- Will not corrode
- Longer life
- Normal fittings can be used
- Lightweight and extremely strong
- Hygienic, environmentally friendly
- Complies to Byelaw 30

Construction

This liner has been manufactured from top quality glass fibre, impregnated with polyester resin. All materials are WRC approved.

Units have a clean, smooth internal finish.

Connections

Original connection points may be used to **save costs of re-piping original pipework**.

Alternatively holes for new connections may be cut with conventional tools.

Holes must be a snug fit.

Insulation

Tanks can be integrally insulated with Rigid Polyurethane Foam encapsulated in GRP on the interior of the tank wall. Thus, protecting and preventing future removal and damage. This is available in several thicknesses giving corresponding U values.

Maintenance Dividers

Dividers can be installed within the tank(s) to enable maintenance work without a shut down period.

Quality & Testing

All GRP DECCAbords are manufactured by our experienced workforce. During manufacture our products have been subjected to quality control inspections at several stages.

On completion of the installation of the reline and refitted connection points - our experienced site operatives will return to site to commission your tank(s).

Certificates will be issued on handover and DECCAkare Operations and Maintenance Manuals will be issued on completion of contract.

This site test is a condition of our guarantee.

Other Products

- Non-standard one-piece tanks
- Two-piece tanks
- Sectional tanks
- Underground tanks
- Tank housings
- DECCAkare Service Maintenance Contracts

New Byelaw 30 covers

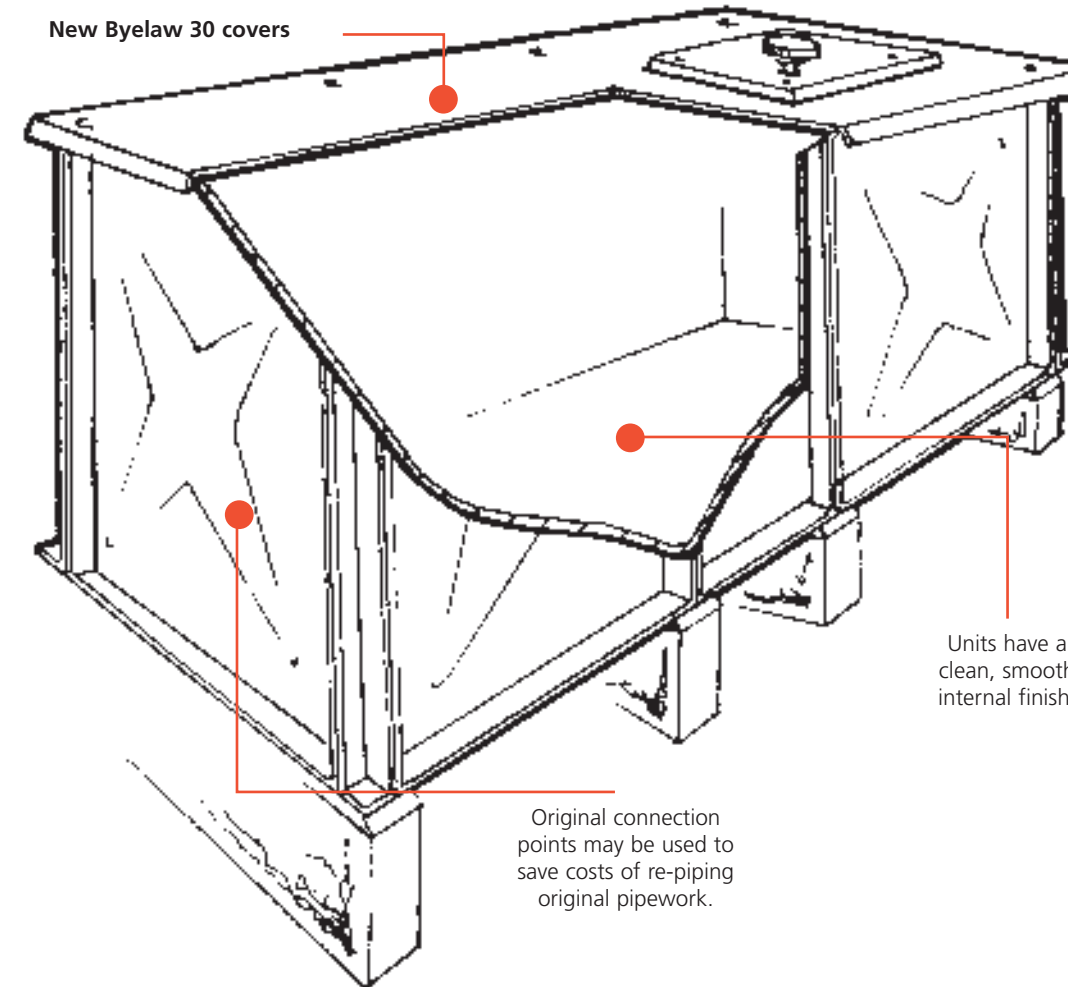

Units have a clean, smooth internal finish.

Original connection points may be used to save costs of re-piping original pipework.

Tank Painting

DECCAbords

After

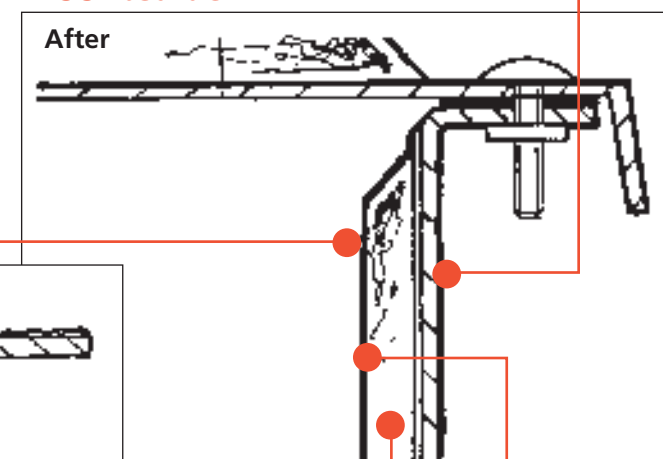

Before

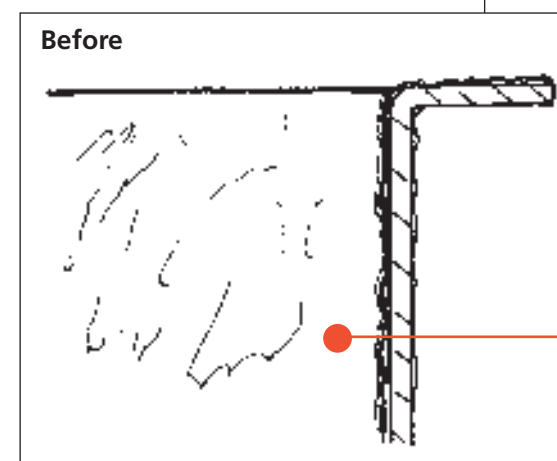

Insulation
GRP DECCAbording
Rust & dirt on internal surface of tank poor water quality.